

Open 75mm Pile Cage Spacer

OPEN PLASTIC WHEEL SPACER FOR PILING

GREEN BUILDING
100% Recycled Material

EASY TO WORK
No wire ties



PRODUCT NAME	Open Pile Cage Spacer
PRODUCT TYPE	Open Wheel Spacer
PRODUCT REFERENCE CODE	OPS75
COVER HEIGHT	75 mm (3")
REBAR DIAMETER	10-20 mm (#3-#6)
SPACER WEIGHT	66 grams (2.3 oz)
MATERIAL	Polypropylene (PP)
COLOR	Black
PACKING QUANTITY	200 pcs



DESIGN

Fully compliant to CRSI Manual of Standard Practice (USA)
The product is made of 100% post-consumer recycled content by weight and is 100% recyclable

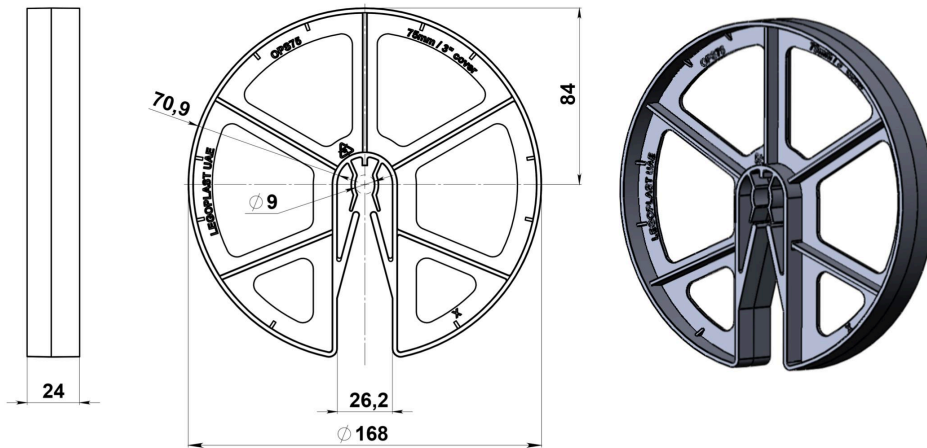

SPECIFICATION

#	Parameter	Unit	Value
1	Concrete cover	mm	75 (3")
2	Bar size (diameter)	mm	10-20 (#3-#6)
3	Item weight	gm	66 gm (2.3 oz)
4	Height	mm	168 mm (6.61")
5	Width	mm	168 mm (6.61")
6	Depth	mm	24 mm (0.95")

PRODUCT DESCRIPTION

The OPS75 open pile cage spacer (circular or wheel spacer) is designed to provide a 75 mm (3") cover and spacing for pile cages in reinforced foundations such as in situ piling and diaphragm walls. It acts as a guide wheel when lowering the reinforcement cage into the ground, ensuring smooth sliding and compliance with concrete cover requirements. The OPS75 is attached to the external steelwork (rebar diameter from 10 to 20 mm, or rebar sizes #3 to #6) of pile cages to ensure correct spacing from shuttering. The product is fully compliant with CRSI Manual of Standard Practice (USA).

FACTORY ADDRESS

Legoplast Plastic Manufacturing L.L.C, 68 Street, warehouse S02 near building 27, Jabal Ali Industrial First, Dubai, United Arab Emirates, Makani № 1157464307, Land DM № (Plot №) 599-1138

Note: This certify that the above item was tested and verified according to Legoplast Plastic Manufacturing L.L.C test procedure.